

Turm 170 HC
tower / le mât
torre
max. 52,5 m

Turm 120 HC
tower / le mât
torre
max. 52,4 m

Turm 71 EC
tower / le mât
torre
max. 34,5 m

Hubhöhen: siehe Tabellen
Hoisting heights: s. tables
Hauteurs sous crochet: v. tableaux
Altezze di sollevamento: vedi le tabelle
Altura bajo gancho: ver tablas
Alturas de elevação: veja-se as tabelas

DIN



Ausladung

Radius / Portée / Sbraccio / Alcances / Alcance

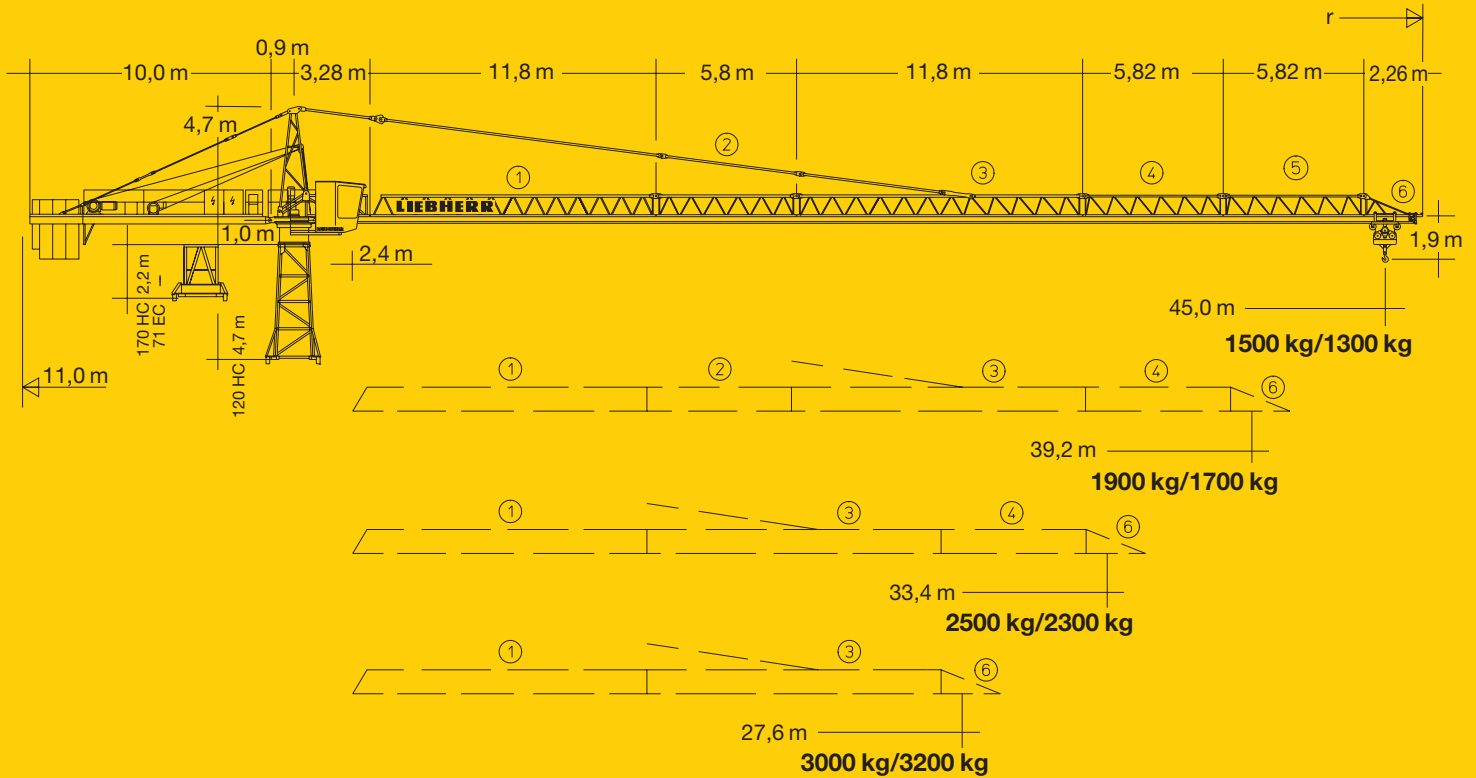

Hubhöhe

Hoisting height / Hauteur sous crochet / Altezza di sollevamento / Altura bajo gancho / Altura de montagem

	170 HC		120 HC	
15	-	-	48,1*	52,4*
14	-	-	45,6	49,9
13	-	-	43,1	47,4
12	-	-	40,6	44,9
11	-	-	38,1	42,4
10	52,5*	-	35,6	39,9
9	48,4*	52,5*	33,1	37,4
8	44,2	48,4*	30,6	34,9
7	40,1	44,2	28,1	32,4
6	35,9	40,1	25,6	29,9
5	31,8	35,9	23,1	27,4
4	27,7	31,8	20,6	24,9
3	23,5	27,7	18,1	22,4
2	19,4	23,5	15,6	19,9
1	15,2	19,4	13,1	17,4
0	11,1	15,2	10,6	14,9
	m		m	

* Weitere Hubhöhen sowie Klettern im Gebäude auf Anfrage. / Further hoist heights and climbing in the building on request.
 Hauteurs sous crochet plus élevées et hissage dans le bâtiment sur demande. / Altre altezze di sollevamento come pure varianti di gru
 allungabili: su richiesta. / Para alturas bajo gancho superiores y trepado en el interior del edificio, consultar. / Outras alturas de elevação
 e subida no edifício: conforme ao pedido.

Hubhöhe

Hoisting height / Hauteur sous crochet / Altezza di sollevamento / Altura bajo gancho / Altura de montagem

		71 EC				
6 m	12 m					
4,2 m	4,2 m	2) 34,5	40,5	40,3	39,5	45,3
* + Grundturmstück		-	36,3	36,1	35,3	41,1
6	3	30,3	30,3	30,1	29,3	35,1
5		1) 24,3	24,3	24,1	23,3	29,1
4	2	18,3	18,3	18,1	17,3	23,1
3		12,3	12,3	12,1	11,3	17,1
2	1	6,3	6,3	6,1	5,3	11,1
1						
<p>Anzahl der Turmstücke Number of tower sections Nombre d'éléments de mât N. elementi di torre Cant. secciones de torre Núm. de peças de torre</p>						

* Für die maximale Hakenhöhe ist das 4,2 m lange Grundturmstück erforderlich. / The 4,2 m long base tower section is necessary to achieve maximum hook height. / Pour obtenir la hauteur sous crochet maxi, il faut monter l'élément de mât de base d'une longueur de 4,2 m. Per ottenere l'altezza max. di gancho, si deve montare la sezione di torre basi di lunghezza 4,2 m. / Para la altura máxima bajo gancho se necesita el tramo base de 4,2 m. / Para alcançar à altura max. do gancho, é necessário utilizar a peça de base de torre de comprimento 4,2 m.



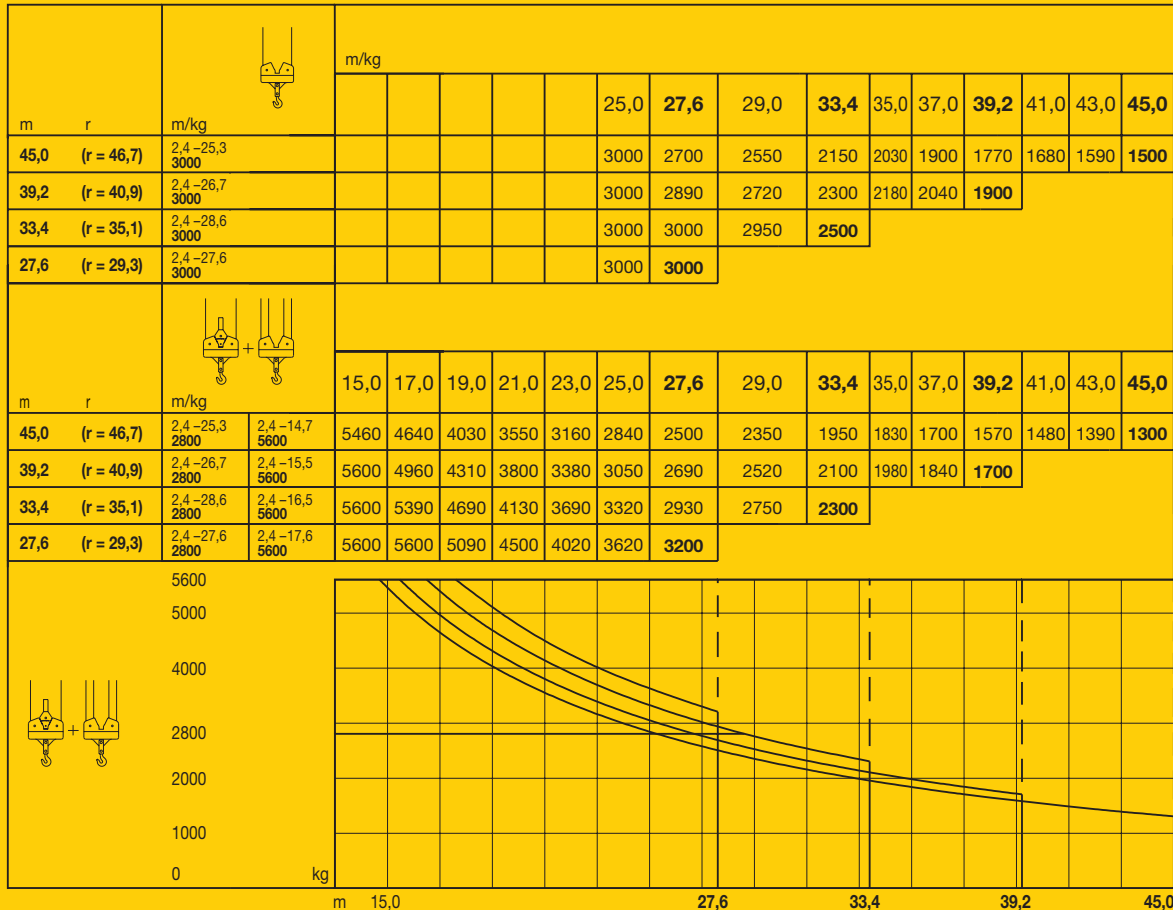

Ausladung und Tragfähigkeit

Radius and capacity / Portée et charge / Sbraccio e portata / Alcances y cargas / Alcance e capacidade de carga

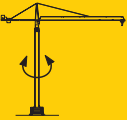

Geschwindigkeiten

Speeds / Vitesses / Velocità / Velocidades / Velocidades

	U/min 0,85 sl./min tr./min	6,3 kW
	8,0 / 29,1 / 54,0 m/min	3,0 kW
	25,0 m/min	2 x 2,2 kW (71 EC) 2 x 3,0 kW (120 HC) 2 x 7,5 kW (170 HC)
	kVA	 22 kW 22 kW, FU 40,0 30,0

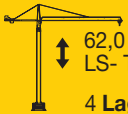
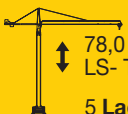
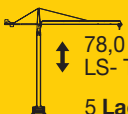
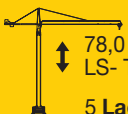















	Stufe / Step / Cran Marcia / Grado Velocidade	kg	m/min
 <p>22,0 / 18,0 / 4,0 kW, KL WIW 220 KY 006</p> <p>62,0 m LS- Trommel</p> <p>4 Lagen Layers Couches strati camadas capas</p>	1	3000	2800 7,6
	2	3000	2800 35,3
	3	1700	1700 70,0
 <p>22,0 kW, FU WIW 230 KY 002</p> <p>78,0 m LS- Trommel</p> <p>5 Lagen Layers Couches strati camadas capas</p>	1	5600	5600 3,6
	2	5600	5600 17,6
	3	3400	3400 35,0
 <p>22,0 kW, FU WIW 230 KY 002</p> <p>78,0 m LS- Trommel</p> <p>5 Lagen Layers Couches strati camadas capas</p>	1	3000	2900 3,6
	2	3000	2900 36,0
	3	2400	2200 44,0
	4	1400	1500 70,0
 <p>22,0 kW, FU WIW 230 KY 002</p> <p>78,0 m LS- Trommel</p> <p>5 Lagen Layers Couches strati camadas capas</p>	1	5600	5600 1,9
	2	5600	5600 19,0
	3	4700	4700 23,0
	4	3100	3100 35,0

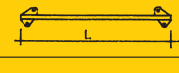

Kolli-Liste

Packing List / Liste de colisage / Lista dei colli
Lista de contenido / Lista de embalagem

Montagegewichte: siehe Betriebsanweisung.
Erection weights: see instruction manual.
Poids de montage: voir manuel de service.
Pesi di montaggio: vedasi le istruzioni sull'uso.
Pesos de montaje: vejam-se as instruções p. uso.
Peso para el montaje: según manual.

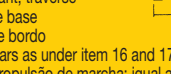
Kranoberteil		Upper part of crane / Partie supérieure de gru Parte superiore della gru / Parte superior grúa Parte superior do guindaste	L (m)	B (m)	H (m)	kg	Einzelgewichte / Single weights / Poids individuels / Pesi di componenti / Pesos de peças componentes / Pesos unitarios.	
Pos. Item Rep. Voce Pos. Ref.	Anz. Qty. Qta. Cant. Cant.	Komplettkrankopf / One-piece machine deck / Tête de grue Testa completa della gru Módulo giratorio / Cabeça compl. de guindaste		12,00	2,44	2,38	9000	
2	1	Übergangsstück / Adapter section Tronçon de conversation / Spezzone collegamento / Tramo de adaptación Peça ligadora		5,00 2,41	2,20 2,50	2,30 2,30	2540 2750	
3	1	Kabine mit Podest / Cabin with platform / Cabine avec plate-forme Cabina con piattaforma / Cabina con plataforma / Cabina com plataforma		3,10	1,30	2,20	610	
4	1	Drehbühne kpl. / Slewing platform cpl. Partie tournante cpl. / Piattaforma girevole compl. / Conjunto plataforma de giro / Plataforma giratória compl.		4,20	1,80	1,97	3280	
5	1	Turmspitze / Tower head section Porte-fleche / Testa porta-braccio Cabeça de apoio de lança / Cabeza de torre		4,55	1,00	1,35	575	
6	1	Gegenausleger kpl. / Counter-jib cpl. Contre-fleche cpl. / Controbraccio, compl. / Contrapluma compl. Contra-lança, compl.		L1 10,20 L2 8,00	1,90	2,32	4070	
7	1	Ausleger-Anlenkstück / Jib heel section / Pied de fleche / Settore articolato di braccio / Base articulada de lança / Pluma tramo primero		12,00	0,97	0,96	① 1300	
8	1 1 1 1	Ausleger-Zwischenstück / Intermediate jib section / Elément interm. de fleche Spezzone di braccio / Peça suplementar da lança / Tramo intermedio pluma		6,00 12,00 6,02 6,02	0,97 0,97 0,97 0,97	0,96 0,96 0,96 0,96	② 685 ③ 1200 ④ 342 ⑤ 280	
9	1	Ausleger-Kopfstück / Jib head Pointe de fleche / Punta freccia Cabeça de lança / Tramo punta de pluma		2,31	0,97	0,93	⑥ 125	
10	1	Lasthaken / Load hook Crochet de levage / Gancio di carico Polipasto / Gancho de suspensão		1,30	0,93	0,26	340	
Turm		Tower / Mât / Torre Torre / Torre						
11		Turmstück / Tower section Element de mât / Elemento di torre Torre / Torre		3,00 6,00 2,50 5,00 4,14	1,20 1,20 1,80 1,80 1,90	1,20 1,20 1,80 1,80 1,90	1080 1480 1090 1830 1850	
12		Turmstück lang / Long tower section Elément de mât long / Elemento di torre, lungo / Tramo de torre largo / Peça de torre, comprida		12,00 10,00	1,20 1,80	1,20 1,80	2610 3425	
13	1	Grundturmstück / Base tower section Mât de base / Elemento di torre base Tramo torre base / Peça de base de torre		4,20 6,85 10,00 9,60	1,20 1,80 1,80 1,90	1,20 1,80 1,80 1,90	1340 2610 3530 4350	
Klettereinrichtung		Climbing equipment / Equipement de télescopage / Attrezzatura per allungamento della gru Equipo de trepado / Acessórios p. subida no edifício						
14	1	Führungsstück kpl. / Guide section cpl. Cage télescopique cpl. / Gabbia de sopraelevazione compl. / Peça de guia compl. / Torre de montaje completa		6,45 9,60 9,04	2,10 2,10 2,31	2,42 2,42 2,28	2660 4410 4750	
15	1	Hydraulikanlage, Stütz- und Klettertraverse / Hydraulic unit, supporting and climbing cross members / Système hydraulique avec traverses d'appui et de télescopage / Sistema idraulico, traversa di appoggio e allungamento gru / Instalação hidráulica, travessa de apoio e subida Sistema hidráulico con traviesa de apoyo y trepado		2,87 2,30	2,12 1,10	1,06 1,00	1800 1100	
Unterwagen		Undercarriage / Châssis / Carro della gru Carro con mástil / Carro de guindaste						
16	2	Fahrschemel mit Antrieb / Rail bogie with drive / Bogie moteur / Telaio con gruppo propulsore / Quadro sem grupo de propulsão / Caja rodillo motriz		0,75 1,38 1,46	0,55 0,88 0,84	0,55 0,87 0,87	307 900 920	
17	2	Fahrschemel ohne Antrieb / Rail bogie without drive / Bogie fou / Telaio senza gruppo propulsore / Quadro com grupo de propulsão / Caja rodillo conducido		0,65 1,17 1,15	0,30 0,60 0,60	0,55 0,87 0,87	222 860 880	
18	1	Tragholm lang / Long support arm Longeron long / Longherone lungo Brazo largo soporte / Travessa comprida		7,12 7,15	0,75 0,80	0,65 0,70	950 1070	
19	2	Tragholm kurz / Short support arm Longeron court / Longherone corto Brazo corto soporte / Travessa curta		3,45 3,45	0,56 0,60	0,55 0,70	408 500	
20	4 2 + 2	Randträger / Border support Traverse / Supporti base Traviesa / Apoio de bordo		4,02 4,08 - 4,30	0,35 0,16 - 0,33	0,12 0,11 - 0,14	95 80 - 200	
21	4	Stützholm / Support strut Hauban de châssis / Correnti di appoggio Tirante vertical / Travessa de apoio		3,78 3,53	0,15 0,25	0,22 0,17	200 240	
22	1	Unterwagen-Turmstück / Undercarriage tower section / Mât de châssis / Elemento di torre del carro / Tramo de carro Peça de torre do chassis		3,50 3,30	2,06 2,15	2,06 2,15	1320 2000	
23	2	Fundamentkruz mit Spindeln, Tragholm lang / Cruciform base with outrigger jacks, long support arm / Châssis en croix avec vérins, longeron long / Base incrociata con aste, longherone lungo / Tramo largo base cruciforme, con husillos Base cruciforme com árvores, travessa comprida		3,8 m 3,0 m	5,80 4,70	0,60 0,60	0,80 0,80	1860 1625
24	2	Fundamentkruz fahrbar, Tragholm lang / Cruciform rail going, long support arm / Châssis en croix roulant, longeron long / Base incrociata mobile, longherone lungo / Brazo soporte largo de base cruciforme para traslación sobre via Base cruciforme móvil, travessa comprida		3,8 m 3,0 m	5,60 4,50	0,60 0,60	0,90 0,90	1750 1510
25	4	Fundamentkruz fahrbar, Randträger / Cruciform rail going, border support / Châssis en croix roulant, traverse Base incrociata mobile, travessa / Traviesa de base cruciforme / Base cruciforme móvil, apoio de bordo (Fahrwerke wie Pos. 16 und 17) / (Travel gears as under item 16 and 17) / (Mécanismes de translation comme pos. 16 et 17) / (Gruppi propulsori marcia come da voce 16 e 17) / (Mecanismos de traslación como Pos. 16 y 17) / (Grupos de propulsão de marcha: igual a ref. 16 et 17)		3,8 m 3,0 m	3,40 2,60	0,20 0,20	0,35 0,35	114 91
26	1	Kiste mit Kleinteilen / Crate with small parts Caisse contenant des accessoires / Cassa con accessori Caja con accesorios / Caixa de acessórios		2,00	1,00	1,00	2000	

121 P -3069 H1 B3 DIN 15018 •BGL 2112-0071 •05.99 / 6

Konstruktionsänderungen vorbehalten! / Subject to alterations!
Sous réserves de modifications! / Si fa riserva di modifiche!
Salvo modificação da construação! / ¡Sujeto a modificaciones!